



Single Output With PFC Function

MODEL	ELDV-12E500P	ELDV-24E500P
OUTPUT VOLTAGE	12V	24V
VOLTAGE ADJ.RANG	11.4~13.2V	22.8~26.4V
CURRENT RANGE	0-40 A	0-22 A
INPUT VOLTAGE	90~264Vac 127~370Vdc	
INPUT CURRENT	5.4A@115Vac 2.7A@230Vac	

SELV

INPUT

INPUT VOLTAGE	90~264Vac 127~370Vdc (Refer to the derating curve of "Loading and Input voltage")	
POWER FACTORY	PF>0.95/230Vac PF>0.98/115Vac	
FREQUENCY RANGE	47~63Hz	
EFFICIENCY	92%@12V 94%@24V	
AC INPUT CURRENT	≤5.4A@115Vac	≤2.7A@230Vac
AC INRUSH CURRENT	20A@115Vac	40A@230Vac
LEAKAGE CURRENT	≤2mA/240Vac	

PROTECTION

OVER LOAD	110%-140% rated power, Protection type:>0.2s, Shutdown, recovers automatically after repower on
OVER VOLTAGE	Protection type:Shutdown, recovers automatically after repower on
OVER TEMPERATURE	Protection type:Shutdown, recovers automatically after temperature goes down

ENVIRONMENT

OPERATING TEMPERATURE	-30°C~+70°C (Refer to the derating curve of "Loading and Ambient temperature")
OPERATING HUMIDITY	20~90%RH non-condensing
STORAGE TEMP, HUMIDITY	-40°C~+85°C 10%~95%RH

WEIGHT & PACKING

MTBF	≥200Khrs.MIL-HDBK-217F(25°C)
PRODUCT DIMENSION	230x127x40.5mm(L*W*H)
NET WEIGHT	1.3KG
QUANTITY/CARTON	9PCS
GROSS WEIGHT	12.7KG

AN ON/OFF CONTROL(TYP.)

RTH2 ≥50°C FAN ON, ≤40°C FAN OFF

Features:

- Universal AC input 90~264Vac
- Built-in active PFC function
- Protections:Short circuit / Overload / Over voltage / Over temperature
- Fan less design
- 1U low profile 40.5mm
- Remote control/power good(fail)
- Redundant (for ELDV-500P)
- 100% full load burn-in test
- LED indicator for power on
- High efficiency/High reliability
- 3 years warranty
- Compliance to IEC/EN/UL 62368-1



OUTPUT

DC OUTPUT	12V	24V
OUTPUT CURRENT	40A	22A
RATED POWER	480W	528W
VOLTAGE TOLERANCE	±1.0%	
RIPPLE NOISE	150mV P-P(Max.)	200mV P-P(Max.)
SETUP RISE TIME	1500mS,50mS@230Vac 3000mS,50mS@115Vac	

SAFETY & EMC

SAFETY	UL62368-1, EN62368-1, GB4943.1
WITHSTAND VOLTAGE	I/P-O/P:3KVac;I/P-FG:2KVac;O/P-FG:0.5KVac
ISOLATION	100M Ohms/500Vdc/25°C/70%RH

	Parameter	Standard	Test Label/Note
	EMI	Conducted emission	BS EN/EN55032(CISPR32),FCC PART 15/CISPR22,GB9254.1
Radiated emission		BS EN/EN55032(CISPR32),FCC PART 15/CISPR22,GB9254.1	Class B
Harmonic current		BS EN/EN61000-3-2, GB17625.1	Class A
Voltage flicker		BS EN/EN61000-3-3	-----
EMS	BS EN/EN55035		
	Parameter	Standard	Test Label/Note
	ESD	BS EN/EN61000-4-2	Level 4,8KV air,Level2, 4KV contact,criteria A
	RF field susceptibility	BS EN/EN61000-4-3	Level 3, criteria A
	EFT bursts	BS EN/EN61000-4-4	Level 3, criteria A
	Surge susceptibility	BS EN/EN61000-4-5	Level 3,1KV/L-N,2KV/L/N-FG criteria A
	Conducted susceptibility	BS EN/EN61000-4-6	Level 3, criteria A
	Magnetic field immunity	BS EN/EN61000-4-8	Level 4, criteria A
Voltage dips and interruptions	BS EN/EN61000-4-11	>95% dip 0.5 periods,30% dip 25 periods,>95% interruptions 250 periods	

LOADING AND AMBIENT TEMPERATURE

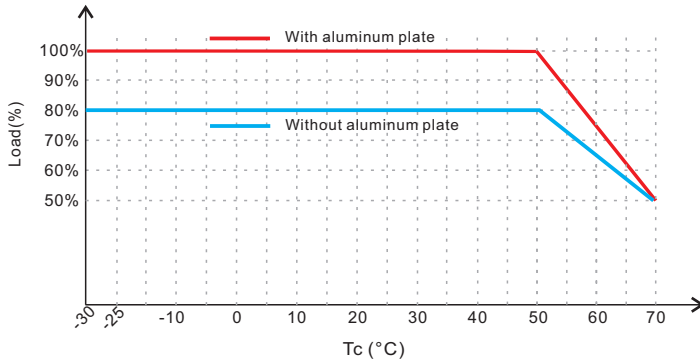

LOADING AND INPUT VOLTAGE

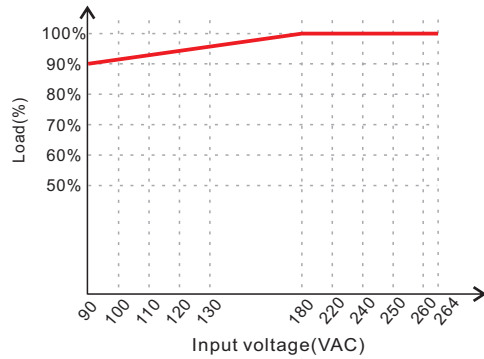

INSTALLATION GUIDE

Product is for indoor use.

- The power supply must be grounded before installation and power on.
 - Short circuit or overload will cause power supply protection, resulting in abnormal operation of the load (LED, instrument equipment, etc.).
 - Maintaining good ventilation and heat dissipation is crucial to the lifespan of the power supply. Do not install the product in a sealed high-temperature environment or near flammable and explosive materials. Do not block the power supply vent with foreign objects.
 - The connection line between the power supply and the load should be as short as possible. A connection line that is too long or too thin will cause a voltage drop on the line, resulting in insufficient LED brightness, uneven lighting, etc.
 - The product has low voltage and high current. Be sure to tighten the terminals during installation to avoid heat caused by poor contact.
- When installing the product, try to stay away from environments with relatively high temperatures.

WIRE DIAGRAM

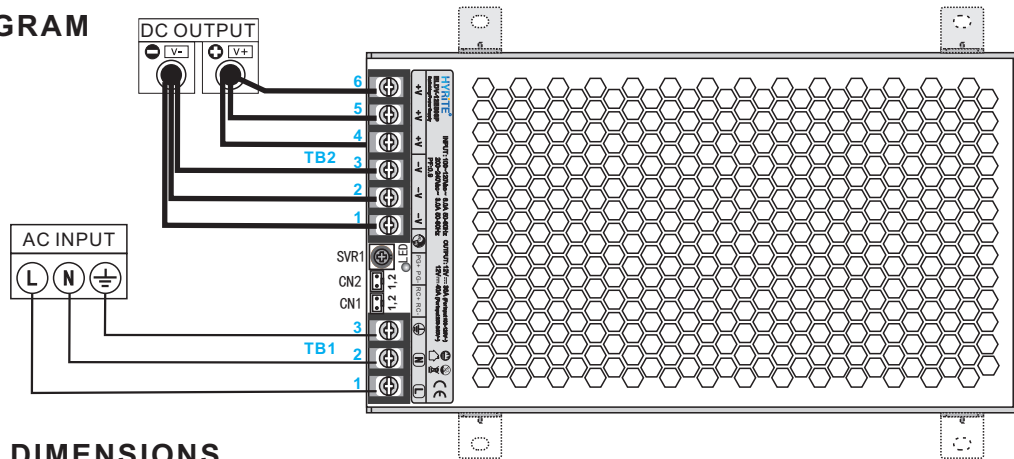

PRODUCT DIMENSIONS

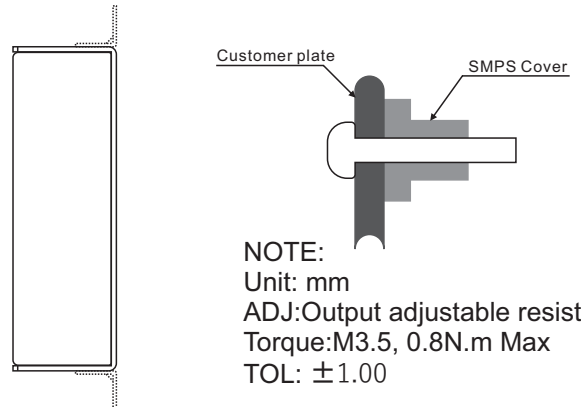
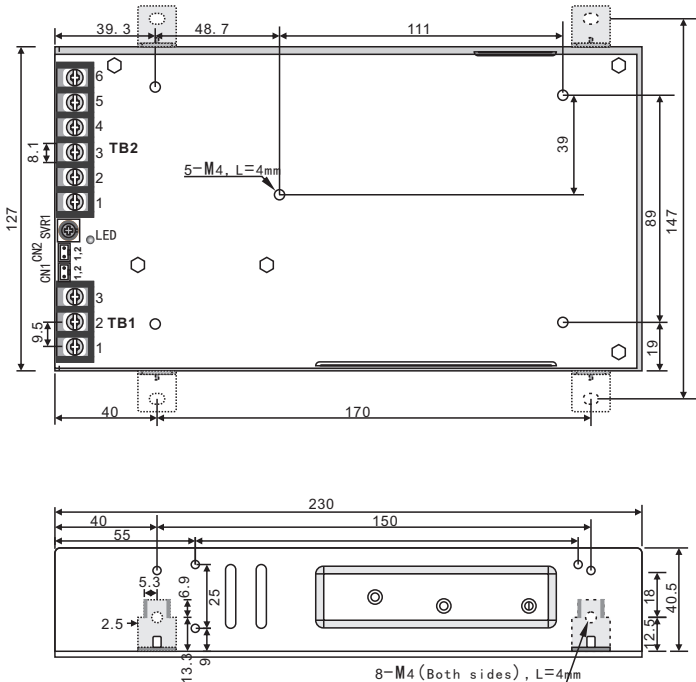

Terminal	Pin No.	Assignment
TB1	1, 2, 3	AC/L, AC/N, FG
	1~3	DC output -V
TB2	4~6	DC output +V
	1/2	RC- / RC+
CN1	CJT A2501WV -2P	RC- / RC+
CN2	CJT A2501WV -2P	PG- / PG+
SVR1		Output voltage adjust

Installation

1. Operate with additional aluminum plate

In order to meet the 'derating curve' and 'static characteristics', ELDV-500P series must be installed onto an aluminum plate (L*W*T: 300mm*300mm*3mm or the cabinet of the same size) on the bottom. The size of the suggested aluminum plate is shown as below. And for optimizing thermal performance, the aluminum plate must have an even and smooth surface (or coated with thermal grease), and ELDV-500P series must be firmly mounted at the center of the aluminum plate. There are two ways to fix it.

Method 1

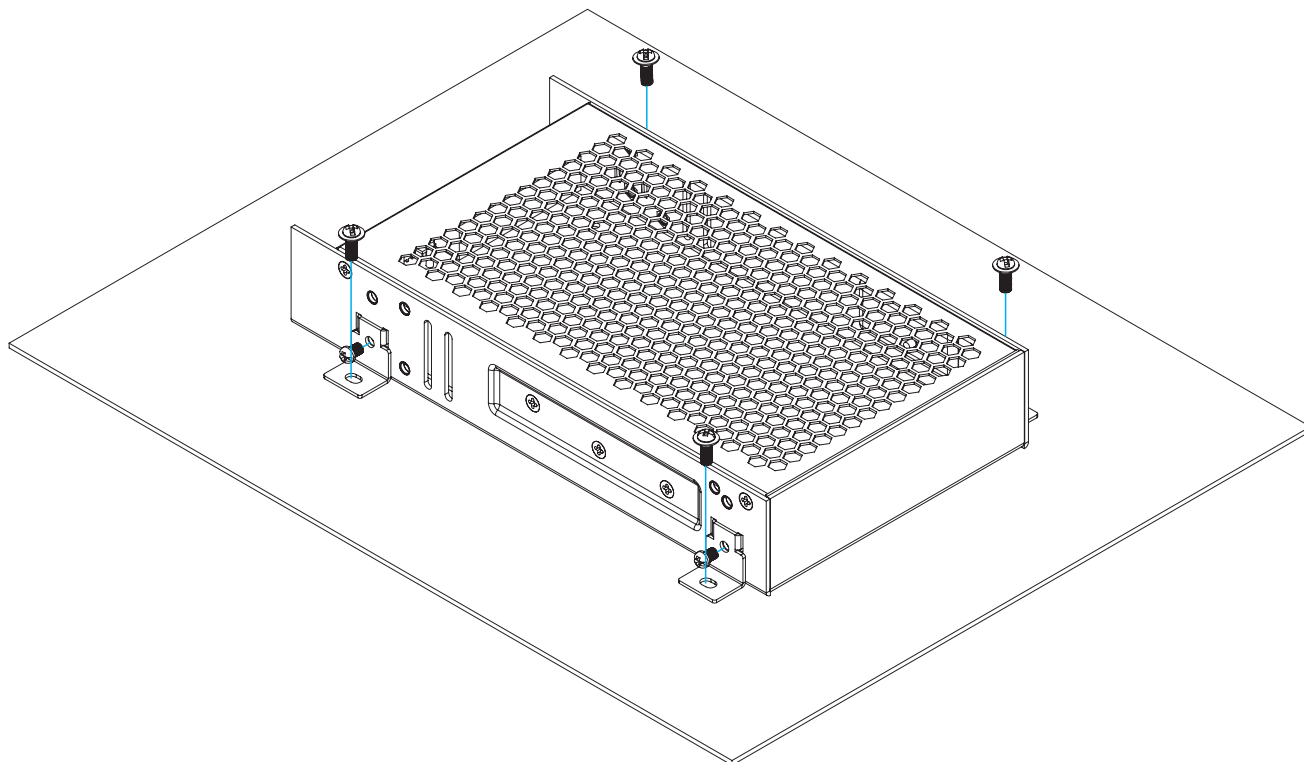

Method 2

